

Miniature Fiber Optic Sensors: from Human to Structural Health Monitoring

Daniele Inaudi¹, Régis Blin¹

¹ SMARTEC SA, Manno, Switzerland

ABSTRACT: Miniature optical fiber sensors, based on Fabry-Perot technology, have found numerous applications in both patient monitoring and civil structural monitoring. Although structural health monitoring and patient monitoring may benefit from the unique advantages of optical fiber sensors (OFS) such as electromagnetic interferences (EMI) immunity, sensor small size and long term reliability, both applications are facing very different realities. This contribution presents the underlying sensing technology, the miniature sensor fabrication technique and numerous application examples in medical and in civil engineering fields.

OFS for medical applications are single-point, measuring mainly vital parameters such as pressure or temperature. In the intra-aortic balloon pumping (IABP) therapy, a miniature OFS can monitor in situ aortic blood pressure to trigger catheter balloon inflation/deflation in counter-pulsation with heartbeats. Similar sensors reliably monitor the intracranial pressure (ICP) of critical care patients, even during surgical interventions or examinations under medical resonance imaging (MRI). Temperature OFS are also the ideal monitoring solution for such harsh environments.

The same miniature sensing elements can be packaged differently to allow their use in civil and geotechnical monitoring. In particular Fabry-Perot optical sensors have been in use for many years as direct replacement of conventional sensors based on the vibrating wire and other electrical technologies. Those sensors are ideal to measure strain, displacement, pressure and temperature in applications subject to strong electromagnetic fields, lightning strikes or requiring long cables. Application examples include the monitoring of groundwater pressures in tailing dams used for mining applications in Chile, leaks in levees in Netherlands and displacements in the cryogenically cooled superconducting magnets for the ITER project in France.

1 FABRY-PEROT INTERFEROMETRIC SENSORS

The fiber optic sensors described in this document are based on the Fabry-Perot interferometry (FPI) process of a light signal, which is accurate in the determination and measurement of a mechanical cavity. This principle is reduced to a white light signal which travels along a fiber, bounces back against a semi-transparent mirror located at the close end of the fiber, trespasses this boundary and covering the path of the cavity or separation for finally bouncing back on a second fully mirrored element. This second mirror is attached to a movable or deformable element, closing or opening the gap of the cavity and producing a second peak in the light path

which is bounced back to the recording instrument. The light is expanded and fed through a Fizeau interferometer, where the opening of the cavity or gap is accurately reproduced and measured, as indicated Figure. 1 and finally recorded on a Charge-Coupled Device (CCD) array. This procedure may be repeated at high frequencies, allowing static and dynamic measurements with the same sensor.

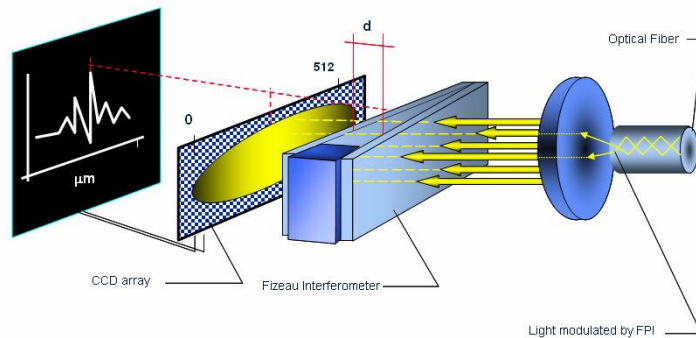

Figure 1. The Fizeau Interferometer in the Fabry-Perot measuring principle.

Considering the precision of measurement of the cavity, the interferometer is provided with a wedge type opening, which allows the division of the full span of any cavity to be determined with high accuracy, and be registered and digitized into a file. The instruments to be implemented through this principle are of the most varied sorts, and include strain gages, piezometers, thermometers, pressure gages, large deformation gages, the measurand depending on the physical mounting of the semi-transparent and fully reflecting mirrors fixed at the terminal of the fiber. The signal carrying fiber may actually have lengths of + 4 000 meters.

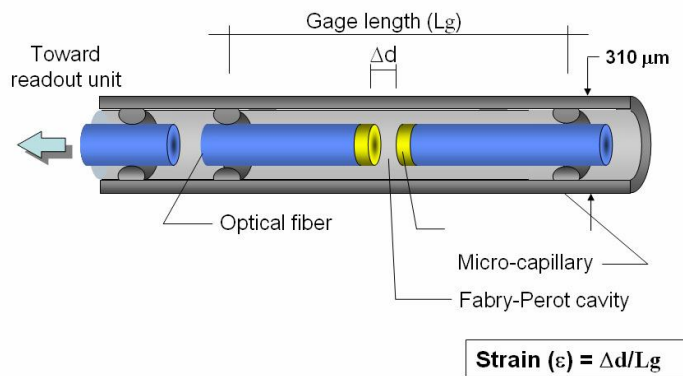

Figure 2. The Fiber Optic Strain Gage.

The strain gage, where the gage length is the distance between the two fixing points of the fiber with the flexible deforming exterior tubing (0.3 mm in diameter), is provided with the semi-transparent mirror attached on the left side and the fully reflecting mirror system fixed on the right hand side, Figure 2. The deformation of the base material to be measured is transferred as

displacement to the micro tubing and the extension of the fibers reproduce this movement in the mirrored cavity, which can be determined with accuracy as indicated in the measuring principle. The data is obtained simply with the indicated algorithm.

The strain gage shown can be compensated for temperature variation, allowing just a different setup of the small mirrored fibers and/or the constituent materials of the dummy right hand side extension piece, which will keep the opening of the cavity equal, independent of the temperature expansion of the full gage. This feature allows complicated measurements to be performed without corrections and with high accuracy.

The basics of the operation of a fiber optic piezometer where the cavity is defined by the semi-transparent mirror of the fiber end and the mirror fully reflecting is part of the flexible diaphragm, which deflects with the hydraulic pressure acting from the wet or right hand side of the sensor, Figure 3. Different stiffness of the diaphragm allow varied pressure ranges for the piezometers as well as coarse and fine porous elements to keep the wet side of the piezometer free of solid particles. The filter is designed to be easily removable for saturation.

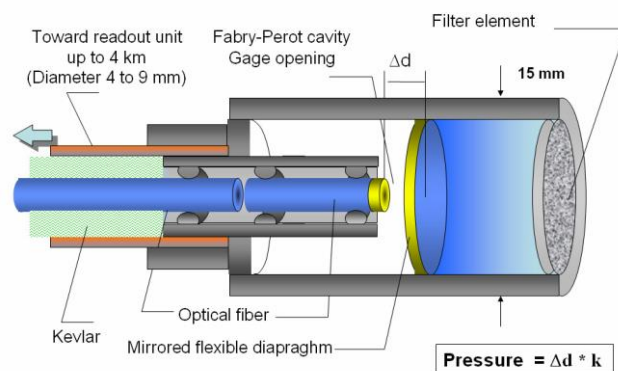

Figure 3. The Fiber Optic Piezometer.

The fiber optic thermometer uses the same principle indicated in the aforementioned sensors and whose capillary unit is complemented with protective tubing, which ensures no strain on the measurand. All deformation on the cavity is produced by the thermal expansion of the capillary tube, having a simple reduction algorithm to convert the expansion directly to temperature, different types of housing and materials expand the measuring ranges according to the particular application, Figure 4. The compact size of the temperature transducers, together with their resistance to corrosive environments, makes them suitable for temperature measurements in harsh environments.

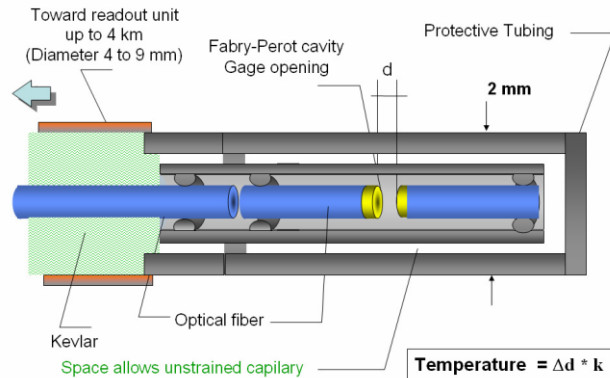

Figure 4. The Fiber Optic Thermometer.

Fiber optic strain gage, temperature sensors, displacement sensor and piezometers are packaged in rugged enclosure for civil engineering applications, Figure 5.



Figure 5. Fabry-Perot sensors (upper strain sensors, lower displacement and piezometers).

2 APPLICATIONS

2.1 Compact pressure sensors for medical applications

The trend toward further reduction of sensor size is particularly true for medical applications. The added value of integrating miniature pressure OFS into instrumented catheters is now clearly accepted in fields like cardiology where the sensor provides precise in situ blood pressure measurements. Such applications involving disposable medical devices, like for instance in intra- aortic balloon pumping therapy (IABP) or in fractional flow reserve (FFR)

evaluation, require low-cost still high-quality sensors manufacturing capabilities. Those sensitive sensors (with flexible diaphragm made from thin silicon) are mass-produced on wafers using well-controlled photolithographic technologies and individually assembled at the tip, e.g. Pinet (2011).

2.2 Operational monitoring of the sand deposit procedure in dams

The operation of tailing dams, typical of mining operations, in their construction phases includes the hydraulic deposit of the sand, which will form the retaining structure of the reservoir. This deposit phase is programmed, forming thin layers of coarse, clean sand which is further compacted. This volume dries out the excess water to accept the next layer. This system has shown to be cost and quality effective, and has been used for the last century, changing from an upstream to a downstream deposition method, which has proven to be safer for the retaining structure under seismic conditions. The area of deposit of the sand is moved along the dam in order to assess the dissipation of the transport water, which has to evaporate and/or drain into the underlying compacted sand strata. At the initial state of the dams, the sand deposition is not simple for the operators, as the cyclone plant, which selects the coarse sand fraction from the fine silty slime, has an excess elevation pressure due to their physical locations, the deposit area is very small, the runs for dissipating the excess water are very short and the surplus water tends to accumulate over the horizontal drains, with possible clogging the open drainage matrix. A tight control of the presence of water in the base of the dam by means of 10 fiber optic piezometers located some 2 meters above drainage layers becomes of major importance in the initial stages of operation, Figure 6.

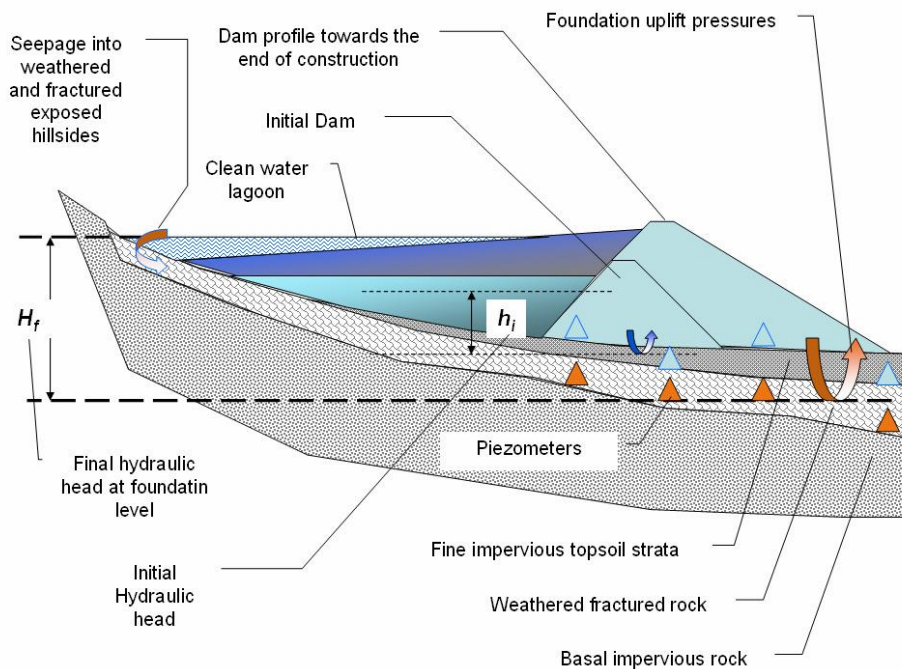

Figure 6. The hydraulic condition of a tailing dam.

The fine slimes are deposited into the basin, usually at a close location to the retaining dam, which allows to naturally select the remaining coarse fraction to be in close contact with the dam profile and later moves to the far upstream side, where the water separates from the fine sand is pumped again into the process, forming a lagoon against the natural hillsides of the reservoir. The hydraulic conditions of a tailing dam are changing during the different construction stages and have to be addressed with a monitoring layout, which will allow the most of the variables to be recorded and controlled during the active and passive phase of the basin.

The solution has successfully been implemented on numerous projects, as the El Mauro Tailing Dam in Chile, e.g. Fahrenkrog (2012) or Fahrenkrog (2007).

2.3 *Dike monitoring control*

Thanks to the advances in miniature fiber optic pressure sensors, driven by the needs of the medical industry, it is now possible to produce extremely small sensors that match and sometimes exceed the sensing properties of conventional piezometers, e.g. Pinet et al. (2007).

Compact size, outstanding metrological performances, resistance to chemicals and to lightning strikes of fiber optic pressure sensors have allowed implementation of an innovative dike monitoring control system in the Netherlands. An array of compact fiber optic piezometers is implemented to permanently keep the dike condition monitored, Figure 7. This system has been tested on a small scale and it is now used for length of about 20 km or more. Besides monitoring the system can intervene if necessary. If the embankment to be wet, for example, by storm or flood, then it puts automatically into operation a small pump that drains water through the filter pipe, e.g. Bos et al (2013).

The dike monitoring control system prevents dike failures due to pipping; pipping occurs due to the entrainment of soil particles by the erosive action of seepage flow. In the beginning, this process is very slow, but the leaching of soil particles go faster and faster, creating a continuous canal. When piping is not being decelerated it weakens the ridge, with the result that the ridge can sag and eventually break. The system with the fiber optic piezometers and filter tube prevents piping.

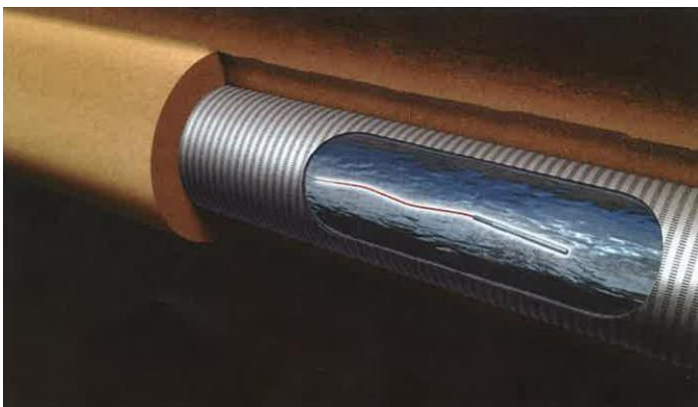

Figure 7. Compact fiber optic piezometer for dike monitoring.

Selection criteria to implement fiber optic piezometers technology are its extremely small diameter (5 mm including housing) and length (54 mm), Figure 8, for installation directly in the

small diameter drain, high precision in the order of 1.5 mm H₂O, temperature sensitivity lower than 1 mm H₂O/°C, long term drift lower than 20 mm H₂O. The sensing element and the transmitting optical fiber are made of inert materials, very resistant to almost all chemicals, e.g. Rodrigues et al. (2010).

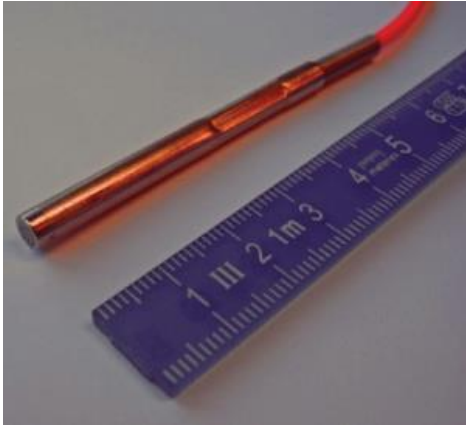

Figure 8. Photo of the fiber optic piezometer integrated into a stainless steel tubing.

2.4 *International Thermonuclear Experimental Reactor (ITER)*

ITER will be the world's largest experimental facility to demonstrate the scientific and technical feasibility of fusion power. Fusion is the process which powers the sun and the stars. When light atomic nuclei fuse together to form heavier ones, a large amount of energy is released. Fusion research aims at developing a prototype fusion power plant that is safe and reliable, environmentally responsible and economically viable, with abundant and widespread fuel resources. ITER is based on the “Tokamak” concept, in which the fusion fuel is contained in a doughnut-shaped vessel. The fuel - a mixture of deuterium and tritium, two isotopes of hydrogen - is heated to temperatures in excess of 100 million degrees, forming a hot gas “plasma”. The plasma is kept away from the walls by a strong magnetic field produced by superconducting coils surrounding the vessel and an electrical current driven in the plasma.

The ITER superconducting coils and structures (Toroidal Field coils (TF), Central Solenoid (CS), Poloidal Field coils (PF), Correction Coils (CC) and Feeders), representing a total weight of approximately 10 000 tons, are submitted to gravitational and seismic forces, stresses induced by constrained thermal contractions during cool-down from 300 K to 4.5 K, and large Lorentz forces in the superconducting coils.

The (strain, displacement, temperature) sensors used to monitor the thermo-mechanical behavior of the structures have to operate under unique and very severe conditions (cryogenic temperatures, large magnetic fields, vacuum, high radiation doses and electro-magnetic noise), e.g. Poncet et al. (2012). The near 1000 measuring points for thermo-mechanical data of the ITER magnet structures will rely for 80% fiber optic sensors. These include sensors using Fabry-Perot technology, in particular for displacement measurement, Figure 9.



Figure 9. Fiber optic displacement sensor for ITER and cryogenic testing.

3 CONCLUSION

Fiber-optic sensors are reliable tools for health monitoring in a variety of applications ranging from the human body to civil structures or works.

However, since adapted sensors solutions responding to application and market oriented specific needs are usually required, many products often require custom design. This is usually not a big challenge when the optical sensing core technology already exists commercially. Most of the customization often targets mainly sensors' packaging, system deployment, data acquisition management and data processing. This bundle of expertise and long-time experience from the Smartec and its sister companies Roctest and FISO, altogether currently the largest supplier of optical fiber systems worldwide, will help to expand this market. With the proliferation of fiber-optic sensors that have now started to be mass-produced in order to respond to the medical and civil engineering market needs, optical fiber sensing technologies is becoming more and more accessible for an increasing number of applications. Now that products and technologies are more recognized and better accepted by the end-users communities, fiber optic sensors will further expand in markets in which their theoretical and technical advantages over other competitive sensing technologies are already apparent.

4 REFERENCES

- Bos, HJ, Wiering, H, van der Meer, MT, 2013, Continue monitoring voor Ommelanderzeedijk, *Land+Water NR.5 (Dutch)*
- Fahrenkrog, C, Fahrenkrog, A, 2012, Instrumentation with Fiber Optic Sensors emphasizing Operation of Tailing Dams and Landfill monitoring, *5th European Conference on Structural Control, Genoa, Italy*
- Fahrenkrog, C, 2007, Instrumentation with Fiber Optic Sensors Emphasizing Operation and Closure of Tailing Dams, *Proceedings of the Second International Conference on Mine Closure, Santiago, Chile*
- Pinet, E, 2011, Pressure measurement with fiber-optic sensors: Commercial technologies and applications, *21st Optical Fiber Sensors (OFS) Conference, Ottawa, Canada*
- Pinet, E, Hamel, C, Glišić, B, Inaudi, D, Miron, N, 2007, Health Monitoring With Optical Fiber Sensors: from Human Body to Civil Structures, *14th International Symposium SPIE Smart Structures and Materials & Nondestructive Evaluation and Health Monitoring, San Diego, California USA*
- Poncet, A, Rodriguez-Mateos, F, Inaudi, D, Belli R, 2012, Fibre Optic Sensors for the Thermo-Mechanical Instrumentation of the ITER Magnets, *5th European Conference on Structural Control, Genoa, Italy*

SMAR 2017 – Fourth Conference on Smart Monitoring,
Assessment and Rehabilitation of Civil Structures

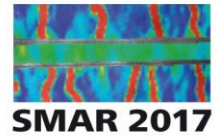

Rodrigues, C, Inaudi, D, Juneau, F, Pinet, E, 2010, Miniature Fiber-Optic MOMS Piezometer,
Geotechnical Instrumentation News