

## The use of innovative FRP Anchorages to improve the performance of Box Girder Bridge retrofit projects

R. Al-Mahaidi<sup>1</sup>, R. Kalfat<sup>1</sup> and G. Williams<sup>2</sup>

<sup>1</sup>Faculty of Engineering and Industrial Sciences, Swinburne University of Technology, Hawthorn, Vic, Australia, 3122

<sup>2</sup> West Gate Bridge Strengthening Alliance, Sinclair Knight Merz (SKM), Melbourne, Australia.

**ABSTRACT:** Many existing box girder bridges are presently being retrofit with fibre composite materials in order to achieve greater flexural, shear and torsion strength and to meet the demands of today's escalating traffic loading. The technical challenges involved with such bridge retrofit projects are investigated herein through a case study of the Westgate Bridge project which is one of Melbourne, Australia's most iconic and important transportation infrastructure linkages. Innovations in FRP conceptual and detailed design involving FRP anchorage technology, implementation, testing and monitoring have resulted in world class practices in the area of large scale FRP implementation. Efficient FRP anchorage solutions developed specifically for this project, involved the use of unidirectional and bidirectional fabrics together with mechanical substrate strengthening. These solutions have resulted in increased fiber utilization levels, largely attributed to an enhancement of FRP-to-concrete bond strength and a distribution of fiber-adhesive stresses over a greater area of concrete. The innovations presented herein have potential for wide applications in the increasing number of projects of this nature worldwide.

### 1 INTRODUCTION

The present expansion of civil infrastructure to meet the demands of escalating population growth has resulted in the introduction of higher bridge loading specifications being implemented on many of today's existing bridges. Environmental degradation and stricter bridge design and evaluation specifications (AASHTO 1994; ACI 440.2R-08 2008; CAN/CSA-S6 1988) have contributed to the increasing number of bridge retrofit projects currently underway. A good example of this is the West Gate Bridge in Melbourne (pictured below), Australia, which is currently one of the largest CFRP strengthening projects in the world (Hii & Al-Mahaidi 2006).



(a)



(b)

Figure 1 – (a) View of the West Gate Bridge; (b) view of underside of concrete approach viaducts

The Westgate bridge is Melbourne Australia's most central and iconic structures of primary importance to the national transportation network. The bridge currently services approximately 160,000 vehicles per day compared with only 40,000 vehicles when it opened 30 years ago, with future predictions indicating escalating demands expected. The increased traffic volume is to be accommodated by the introduction of two additional lanes through the main carriage way to cater for peak hour traffic. The upgrade was undertaken as part of a joint alliance, including: VicRoads, Flint & Neill, SKM and John Holland. Once completed, the project will comprise of nearly 40km of carbon fibre laminates along with 11,000 sq. m of carbon fibre fabric applied to the structure. The bridge consists of a central steel box girder cable stay, together with eastern and western approach viaducts composed of segmental pre-stressed concrete box girder sections. Together these components make up the 2.6 km long structure. Three cell pre-cast concrete box segments comprise the approach viaducts, which were assembled segmentally to form the central spine. Pre-cast transverse cantilevers protrude at right angles from the spine to support the remaining width of the deck. These were erected and post-tensioned to the central spine in order to carry a concrete slab constructed from pre-cast panels and in-situ concrete as shown in Figure 2 below.

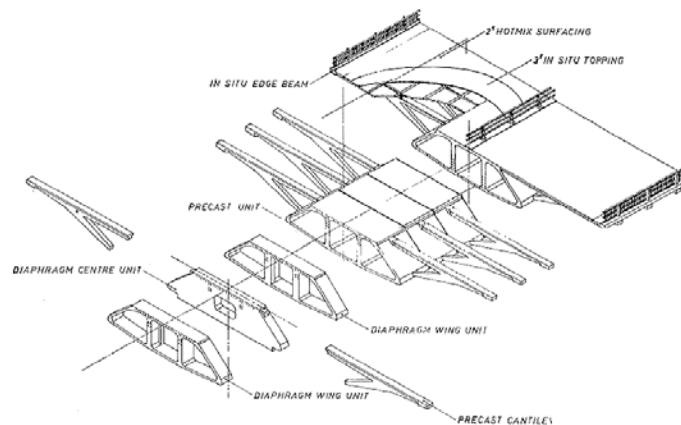

Figure 2 – Exploded View of Concrete Viaduct Components

The scope of the overall strengthening works currently underway on the concrete viaducts include: external post-tensioning applied the concrete box girder for added flexural and shear strength, carbon fiber reinforced Polymers (CFRP) applied to the box girder spine to provide additional the shear and torsional capacity. CFRP was also applied to the protruding cantilevers for increased flexural strength. In current bridge strengthening applications, FRP systems have been proven to be a suitable material for the retrofitting of existing structures. These materials are excellent for external strengthening because of their high tensile strength, light weight, resistance to corrosion, superior durability, and cost-effective installation process when compared with other conventional strengthening systems and procedures. Despite the high tensile strength observed in advanced composites, in externally bonded applications, this strength is little utilized due to the mechanisms of premature de-lamination. This is particularly the case for shear and torsional retrofit applications. Although present design guidelines (ACI 440.2R-08 2008; Concrete Society Technical Report No. 55 2004) usually limit the maximum strain FRP strain level to less than 50% of the materials tensile capacity to prevent such premature failure, it has been found that for heavy shear and torsion strengthening applications this utilization level can be as low as 10-25% (Kalfat & Al-Mahaidi 2010). This was particularly the case for the case study under investigation. Without adequate measures taken to improve the degree of fibre utilization, strengthening using FRP systems may be unpractical and uneconomical in many instances. Such measures to increase FRP material utilization are by appropriately anchoring the ends of the FRP material. Design guidelines such as

(ACI 440.2R-08 2008) recognize the benefits of anchorage systems and permit designers to utilize higher CFRP strain provided that the anchorage device is backed up by sufficient experimental testing (Refer section 11.4.1.2). A specially tailored laboratory research programme was therefore instituted to evaluate the suitability of various CFRP prototype anchorage solutions (Al-Mahaidi, R, Sentry, M & Williams, G 2009) for implementation on the Westgate bridge project, the results from which will be presented herein. Uni-directional and bi-directional CFRP fabrics together with mechanical substrate strengthening were used as the conceptual basis for the devised anchorage schemes which were tested in the laboratory program. The concepts and results presented have potential for use and implementation on similar projects of this nature.

## 2 DESIGN BASIS FOR THE USE OF FRP ANCHORAGE

The complex geometry of box girder bridges together with the requirements for shear and torsional retrofit pose many unique challenges in the area of FRP anchorage and termination detailing where a lack of guidance currently exists in literature. The development of CFRP forces around the corners of the box section and sufficient anchorage of the external CFRP outer web reinforcement into the bridge deck were two critical components in the FRP design termination detailing which required foremost attention. The appropriate anchorage of the externally bonded fibers into the deck and around the corners of the box section should meet the criteria in providing the necessary continuity to engage the torsional tensile stresses in addition to the adequate transfer of shear forces into the bridge deck. The heavy strengthening demands and associated material costs resulted in the additional criteria: to improve the FRP design strains that may be safely utilised in design resulting in material and cost savings. With the above criteria in mind a total of six anchorage schemes were devised and investigated through an extensive laboratory testing program. The intended use of each anchorage type is presented in figure 3.

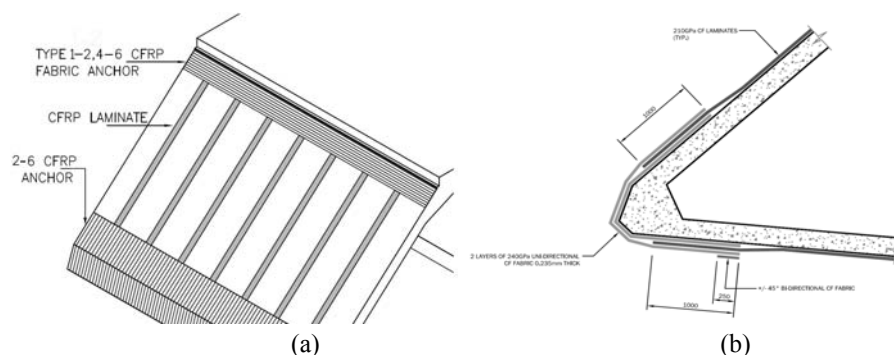

Figure 3: (a) Anchorage types 1 -6 applied to a box girder bridge; (b) Web-Soffit CFRP development detail

2.1 Type 1 – Torsion in box girders typically results in a shear flow through the outer webs of the section. The shear resistance of the outer webs and the girder soffit are both key factors to ensure that the section has adequate strength to resist the applied torsion. The high in plane rigidity of bridge decks means that they seldom need strengthening in practice, however it is of paramount importance that the web-flange connection contain sufficient reinforcement to adequately develop the tensile stresses induced by torsion through the web-flange interfaces. For this purpose, a scheme was devised to install a 24mm diameter reinforcement bar embedded into the underside of the bridge deck to anchor the forces from the ends of the vertical CFRP laminates on the outside webs. The reinforcement bar was installed within a mechanical chase, a byproduct of which was the enhancement of the substrate properties over the length of the anchorage zone resulting in a higher FRP-to-concrete bond strength.

2.1 Type 2 – The concept consisted of utilizing 2 plies of 250mm wide uni-directional CFRP fabric applied horizontally across the end of the laminate and was intended for application at the web-flange interfaces (refer figure 4.0). The direction of fabric fibers were  $90^\circ$  to the direction of laminate. The first sheet of fibre overlaid the second, sandwiching the laminate strip in between. The anchorage was developed in order to assess the effectiveness of unidirectional fabric to resist the tensile peeling stresses in the anchorage zone and to investigate the potential for the distribution of fiber-adhesive stresses over a greater area of concrete, resulting in enhanced anchorage capacity.

2.2 Type 3 – Comprised the application of 2 plies of L-shaped lengths of CFRP unidirectional fabric to the corners of a box section. These were appropriately lapped with a CFRP laminate which was applied to the main faces of the concrete prism (refer figure 3b). The two fold purpose of this design was to sufficiently enhance the anchorage capacity of the CFRP ligatures and to provide the continuous transfer of tensile stresses around the web-soffit joint

2.3 Type 4-6 – Bi-directional fabric was investigated in the remaining anchorages schemes and intended for application at the web flange interfaces. The nature of the bidirectional fabric meant that it could also be successfully applied around the transition between the outer webs and the deck soffit of the box section. The anchorage was expected to provide a more efficient distribution of anchorage bond stresses due the  $\pm 45^\circ$  fiber orientation relative to the direction of the laminate. Anchorage types 4, 5 and 6 represented variations of the same concept involving the application of 1 ply, 2 plies and a combination of uni-directional and bi-directional fabrics respectively.

### 3 EXPERIMENTAL PROCEDURES FOR FRP ANCHORAGE VERIFICATION

#### 3.1 Specimen design

Prior to the construction of the anchorage specimens, an unanchored control sample (type 0) was tested to form the benchmark for later studies. A full scale test set-up was designed using material properties prevalent on site for a comparative study. The factors which were considered in the current testing regime included: the depth of the concrete free edge  $d_c$ , CFRP bond length  $L_f$  and the width ratio between the FRP strip and the concrete prism  $b_f/b_c$ . (Kalfat & Al-Mahaidi 2010) provides a detailed description of these parameters and how they affected the resulting specimen geometry.

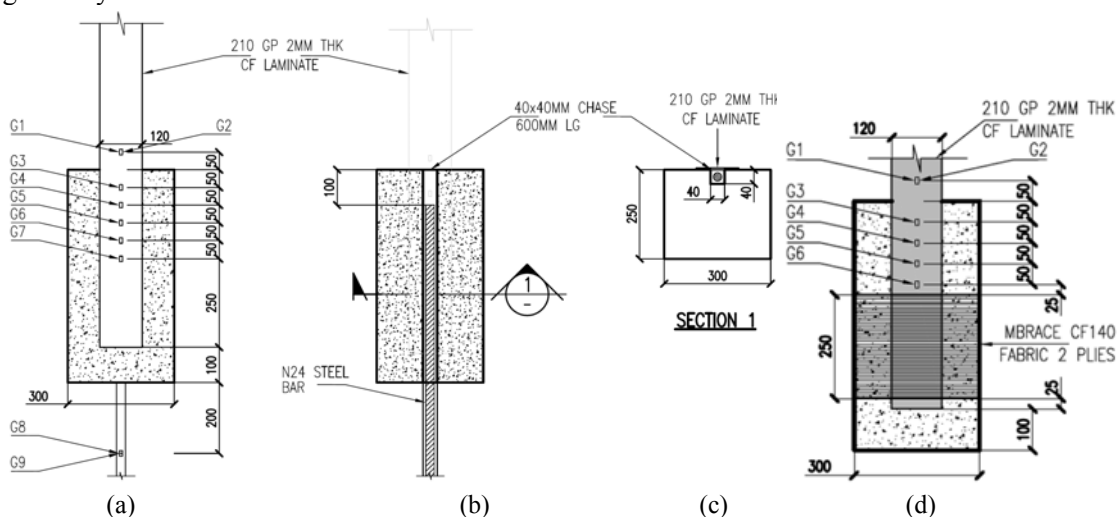

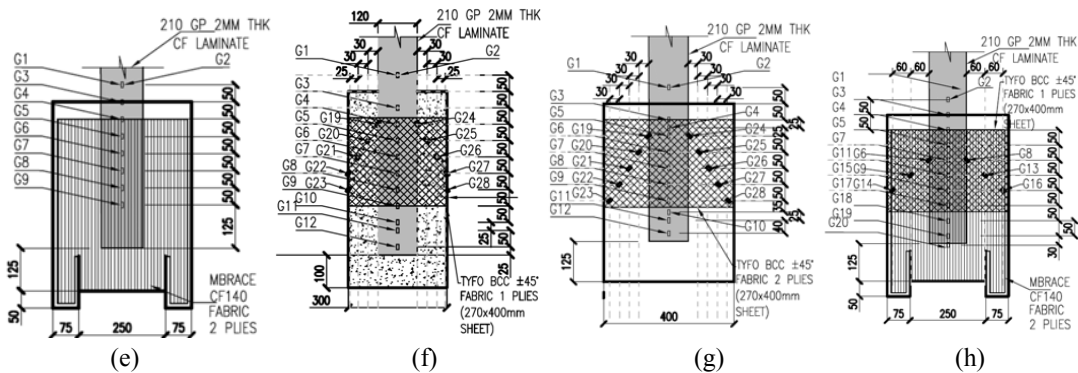

Figure 4: Anchorage types 0 and 2-6 specimen geometry and material properties (a) type 0; (b) type 1 (WG1, WG2); (c) section 1; (d) type 2 (WG35, WG4); (e) type 3 (WG5, WG6, WG7); (f) type 4 (WG12); (g) type 5 (WG10, WG11); (h) type 6 (WG8)

#### 4 EXPERIMENTAL SETUP

Many alternative experimental set-ups have been used by researchers for determining the FRP-to-concrete bond strength. The experimental design used in this study was based on the near end supported (NES) single pull test configuration. (Kalfat & Al-Mahaidi 2010) provides a detailed description of the experimental setup, design and testing procedure.

##### 4.1 Test preparation and material properties

The experimental program utilised two differing concrete prism dimensions suitable for each anchorage type. Types 0, 2 and 4 utilised a total of 4 (type A) reinforced concrete blocks of dimension 250mm x 300mm x 600mm (Figure 4a, 4b, 4d, 4e). Types 3, 5 and 6 utilised 2 (type B) reinforced concrete blocks of dimension 200mm x 400mm x 600mm with a curved end recessed from the base of the prism (Figure 4f, 4g, 4h). Blocks were reinforced nominally with 4 x16mm diameter bars at 200mm centres each face to replicate the existing reinforcement present in the box girder webs. The reinforcement cover used was 30mm. All specimens consisted of a single laminate strip bonded to the surface of the concrete block with a bond length of 500mm for concrete block type A and 425mm for block type B. Table 1 summarises the material properties used in the specimen construction as per manufacturers specifications.

Properties	Laminate Adhesive	Saturant	Bidirectional CFRP ( $\pm 45^\circ$ )	CFRP Laminate	Unidirectional CFRP	Units
Resin Type	Epoxy	Epoxy	-	-	-	-
Glass Transition	>65	-	-	-	-	$^\circ\text{C}$
Compressive	>60	>80	-	-	-	MPa
Flexural Strength	>35	>120	-	-	-	MPa
Lap Shear	>17	-	-	-	-	MPa
Bond (to)	>3.5	>3.5	-	-	-	MPa
Tensile Strength	32	>50	3790	3300	3800	MPa
Tensile Modulus	10	>3.0	230	210	240	GPa
Ult. Elongation	-	-	2.1	1.4	1.55	%
Thickness	-	-	0.55	2	0.235	mm
Width	-	-	-	120	300	mm

Table 1 – Adhesives, Saturant and CFRP Properties data

#### 4.2 Instrumentation and loading procedures

The specimens were loaded under displacement control at a load rate of 1mm/minute. Strain and load results were obtained from surface mounted strain gauges and a 3D non-contact measuring technique based on image correlation photogrammetry (GOM mbH 2005). A series of strain gauges were placed to the CFRP laminate in the locations shown in figure 4. Gauges G1 and G2 were installed at the front and back of the laminate to monitor any bending in the CFRP plate during testing indicating the presence of tilting. G1 was placed at the back of the laminate and G2 at the front at the same location. The 3D photogrammetry measurements were taken using a pair of high resolution, digital CCD (charged couple device) cameras. A measuring step of 10 seconds was used between recording intervals.

#### 4.3 Experimental Results

A total of 6 concrete cylinders were tested to assess the concrete compressive strength. After 53 days curing at room temperature, the average compressive strength of the concrete was 62MP. Pull off tests conducted prior to testing of the specimens indicated that laminate bond failure also occurred within the concrete at a bond pressure of 3.6 MPa. This suggested full bonding between laminate strip and concrete surface. Table 2 summarizes the failure loads and maximum CFRP elongations reached in types 1-6 of the experimental program. In tables and figures which follow reference is made to AR (Photogrammetry) and SG (strain gauge). These refer to the two data acquisition techniques used in the experimental program.

Type	Ref	P <sub>max</sub> (kN)	Max Laminate strain (µε)		Max strain in CFRP ±45° Fabric (SG)		Max strain in CFRP ±45° Fabric (AR)		Max Bond Stress (Zone: 0-175mm from Edge)		Failure Mode
			SG (µε)	AR (µε)	LS (µε)	RS (µε)	LS (µε)	RS (µε)	SG (MPa)	AR (MPa)	
0	WG9	99.6	2535	2706	-	-	-	-	5.2	5.1	CSF
1	WG1	194.4	4640	4434	-	-	-	-	11.3	11.0	CSF/ ASF
	WG2	198.5	4881	4733	-	-	-	-	17.5	10.9	CSF/ ASF
2	WG3	138.2	3242	3212	-	-	-	-	9.57	8.73	CSF
	WG4	142	3142	3235	-	-	-	-	4.35	4.11	CSF/ ASF
	WG5	156.5	3470	3607	-	-	-	-	4.59	5.14	CSF/ ASF
3	WG6	146	3239	3488	-	-	-	-	5.34	5.22	CSF/ ASF
	WG7	145.3	3245	3204	-	-	-	-	6.16	7.71	CSF/ ASF
4	WG12	218.3	5800	4867	12896	13632	13136	-	-	-	CSF / PLR/
5	WG10	213	4900	5261	5228	5225	3982	-	-	-	CSF
	WG11	236.9	5300	-	7433	12834	-	-	-	-	CSF
6	WG8	261.4	7500	7589	4177	4372	4054	-	-	-	PASF/LR

Note: CFS (Cover separation failure); ASF (Adhesive separation failure); PASF (Partial Adhesive Separation Failure); LR (Laminate Rupture); FR (Fabric Rupture); LS (fabric right side of laminate); RS (fabric right side of laminate)

Table 2 – Maximum FRP elongations and corresponding effective FRP strains and utilisation percentiles

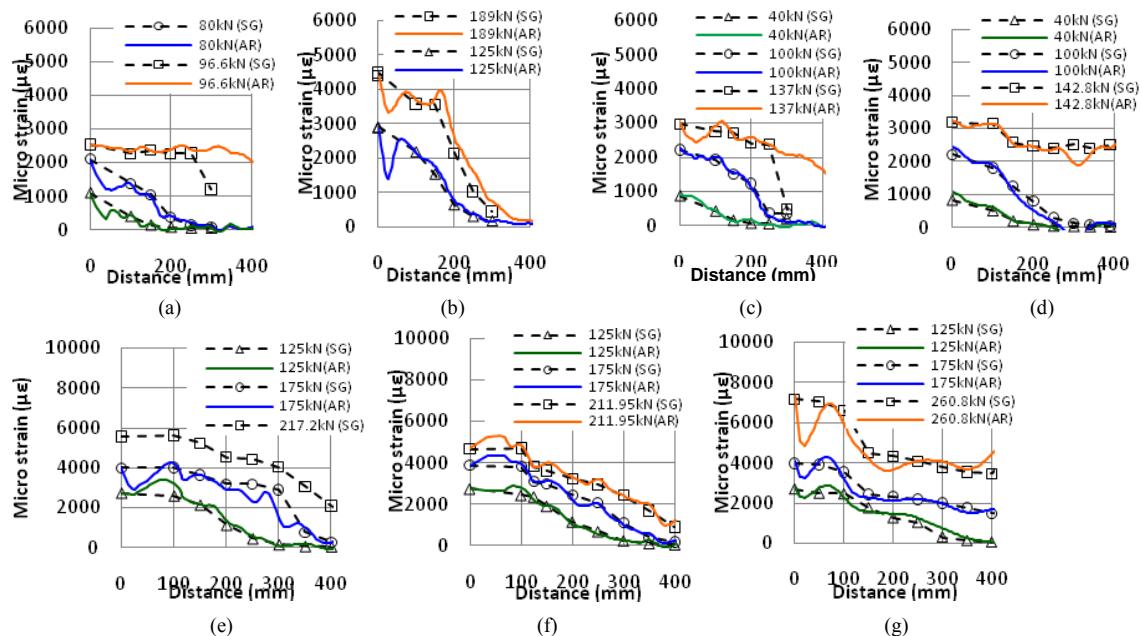

Figure 5: Strain vs distance along Laminate; (a) Type 0 (Control) ; (b) Type 1 (WG1); (c) Type 2 (WG4); (d) Type 3 (WG6); (e) Type 4 (WG12); (f) Type 5 (WG10); (g) Type 6 (WG8);

Results in figures 5 (a)-(g) all show good correlation between photogrammetry and strain gauge measurements. Load - strain relations for the anchorage *type 1* exhibits a steeper slope which is indicative of a stiffer substrate compared to the control sample. A contributing factor was the presence of micro cracking which is believed to have caused a marked reduction in stiffness of the un-strengthened concrete substrate during loading. The results suggest that a mechanical chase cut into the concrete over the anchorage length is an effective way to improve the strength of the concrete substrate, resulting in higher CFRP elongations, bond stress, slip and load carrying capacities reached prior to failure. This is demonstrated by the 95-100% increase in ultimate capacity, 118% increase in bond stress and 83-93% increase in the maximum strain level achieved.

Further examination of the experimental data highlights that anchor type 2, which utilized uni-directional fabric was effective in increasing the ultimate failure load by 39-43% and resulted in an increase in the maximum laminate strain of 19-28% prior to failure. It is evident that specimen WG4 demonstrated no increase in maximum bond stress when compared to the control specimen (refer table 3). It is stipulated that a contributing factor of the higher load carrying capacity observed was the effect of the 50mm adhesive tapers distributing the laminate-adhesive stresses over a greater width of concrete. Further justification for the above was the failure zone of spalled concrete which was observed over a width which was greater than that of the laminate. Additional resistance was also offered by the strut-tie action resulting from the fabric fibres inclining towards the direction of loading prior to failure.

It is believed that the additional strength achieved in anchorage type 3 was due to the transfer of bond stress to a greater distance away from the loaded edge, resulting in an increased effective anchorage length (Al-Mahaidi & Kalfat 2010b). This is clearly observed in figure 5(d) by the higher level of strain recorded at a distance of 300mm away from the loaded face prior to failure. The anchorage effect of developing the CFRP around the curved end of the concrete block using uni-directional fabric facilitated a re-distribution of bond-stress further away from the loaded face, which commenced with the onset of micro-cracking beneath the bond line.

It is noted that an increase in failure load of 128% was observed due to the application of one ply of bi-directional fabric anchored 50mm down the sides of the concrete block (refer figure 2, type 4). A lower increase in failure load of 93-109% was reached in type 5 which utilized two plies of bi-directional fabric, but omitted the 50mm side block anchorage. The bidirectional fabric elongations suggest that the fabric strain utilisations were 2-3 times greater when anchorage down the sides of the block was adopted even when using a lower number of plies. The combination of both unidirectional and bidirectional fabrics adopted in anchorage type 6 utilized the combined benefits of anchorage types 3 and 5 resulting in a distribution of fiber-to-adhesive bond stresses over a greater length and width of concrete. The anchorage showed the greatest increase in ultimate failure load (195%) and failed by rupture of the CFRP laminate at a load of 261.4 KN (Al-Mahaidi & Kalfat 2010a)

## 5 CONCLUSION

The large scale strengthening of box girder bridges poses many unique challenges which have been discussed using the Westgate bridge project as a case study. Efficient FRP anchorage solutions, involving the use of unidirectional and bidirectional fabrics together with mechanical substrate strengthening have been investigated through an extensive laboratory regime. The anchorages presented herein have all resulted in an enhancement of fiber utilization levels, largely related to an enhancement of FRP-to-concrete bond strength and a distribution of fiber-adhesive stresses over a greater area of concrete.

## 6 REFERNCES

- AASHTO 1994, 'Standard Specifications for Highway Bridges', *Washington, D.C., AASHTO*.
- ACI 440.2R-08 2008, 'Guide for the Design and Construction of Externally Bonded FRP Systems for Strengthening Concrete Structures', *American Concrete Institute, Farmington Hills, Michigan*.
- Al-Mahaidi & Kalfat, R 2010a, 'Investigation into CFRP end Anchorage utilising bi-directional fabric wrap', *compos Struct (2010)*.
- 2010b, 'Investigation into CFRP plate end Anchorage utilising uni-directional fabric wrap', *Compos Struct (2010)*, doi:10.1016/j.compstruct.2010.07.012.
- Al-Mahaidi, R, Sentry, M & Williams, G 2009, 'Testing the Efficiency of Anchorage Systems Applied to CFRP Laminate Strips Bonded to Concrete - Westgate Bridge Strengthening Project', *Department of Civil Engineering Report, Monash University, Melbourne, Australia*, no. Dec 2009.
- CAN/CSA-S6 1988, 'Design of highway bridges. Standard S6-88', *Canadian Standards Association, Toronto, Ont.*
- Concrete Society Technical Report No. 55 2004, 'Design guidance for strengthening concrete structures using fibre composite materials, Second Edition', *ISBN 1 904482 14 7*.
- GOM mbH 2005, 'ARAMIS v5.4.1, Gom Optical Measuring Techniques'.
- Hii, AKY & Al-Mahaidi, R 2006, 'Experimental Investigation on Torsional Behavior of Solid and Box-Section RC Beams Strengthened with CFRP Using Photogrammetry', *Journal of Composites for Construction*, vol. 10, no. 4, pp. 321-9.
- Kalfat, R & Al-Mahaidi, R 2010, 'Investigation into bond behaviour of a new CFRP anchorage system for concrete utilising a mechanically strengthened substrate. ', *Compos Struct (2010)*, doi:10.1016/j.compstruct.2010.04.004.